



WE MAGNETISE THE WORLD

COMMERCIAL VEHICLE SYSTEMS



Compressor Clutches

Shaft-mounted Clutches for A/C Compressors

The advantages at a glance

- Easy installation.
- Slim designs possible.
- Weight-optimization possible with aluminum pulleys.
- Service-friendly through use of standard ball bearings.
- Wide range of pulley diameters possible, owing to the ingenious design. Even small pulley diameters possible for increased weight reduction.

Clutches for small 2-cylinder compressors – LA21 / LA28

Applications	<ul style="list-style-type: none"> ■ Bock FK20
Speed	Max. permissible: 3,500 rpm
Voltage	12 V and 24 V



Clutches for large 2-cylinder compressors – LA30

Applications	<ul style="list-style-type: none"> ■ Bock FK30
Speed	Max. permissible: 3,500 rpm
Voltage	12 V and 24 V



Clutches for 4-cylinder and mid-sized 6-cylinder compressors – LA15 / LA16

Applications	<ul style="list-style-type: none"> ■ Bock FKX40 ■ Bock FKX50/460...775 ■ Bitzer 4UFC(Y)...4NFC(Y) ■ Bitzer 6UFC(Y)...6TFC(Y)
Speed	Max. permissible: 3,500 rpm
Voltage	12 V and 24 V



Clutches for large 6-cylinder compressors – LA25 / LA26

Applications	<ul style="list-style-type: none"> ■ Bock FKX50/830 ■ Bock FKX50/980 ■ Bitzer 6PFC ■ Bitzer 6NFC
Speed	Max. permissible: 3,500 rpm
Voltage	12 V and 24 V

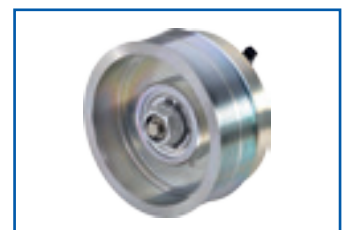

Housing-mounted Clutches for A/C Compressors

The advantages at a glance

- Maintenance-friendly
- Slim designs possible
- No false brinelling, as the bearing rotates both when the clutch is engaged and disengaged.
- Belt forces are absorbed by the compressor housing, relieving the shaft and thus the compressor bearing from belt forces.
- Durable and robust through high wear reserve

Clutches for Thermoking compressors – LA18

Applications	<ul style="list-style-type: none"> ■ X426/X430 ■ S391/S616
Speed	Max. permissible: 3,500 rpm
Voltage	12 V and 24 V



Clutches for Bitzer compressors – LA400 / LA600

Applications	<ul style="list-style-type: none"> ■ F400 ■ F600
Speed	Max. permissible: 4,000 rpm
Voltage	12 V and 24 V



Clutches for Valeo compressors – LA27 / LA21 / LA18

Applications	<ul style="list-style-type: none"> ■ TM65 ■ TM43 ■ TM31
Speed	Max. permissible: 5,300 rpm
Voltage	12 V and 24 V



All compressor clutches optionally available with suppressor diode.

Kendrion A/C Compressor Clutches

Four decades of expertise in drive technology

The LINNIG brand has been around ever since the invention of switchable clutches for A/C compressors. The electromagnetic solution, which initially enabled demand-meeting bus/coach air

conditioning some four decades ago, led to a globally successful Company that to this day sets the standards and always is a step ahead.

Continuous further development of tried-and-tested products

This motto of the Kendrion GmbH also is our mission. As a pioneer in drive technology, we strive in continuously developing our

successful technologies. Our key R&D issues focus on weight, power/load ratio, energy efficiency and service-friendliness.

Demand-meeting bus/coach air conditioning – Innovations for each individual application

When it comes to air conditioning, the solutions that we at Kendrion offer vary to the extent of our customer's requirements.

Our clutches are designed and dimensioned according to application and customer requirements. From the continuously optimized, classic on/off clutch to the two-speed compressor drive, from standard to luxury class, when it comes to demand-meeting

bus/coach air conditioning, our huge array of innovations clearly meet and beat the requirements of each and every customer. Kendrion - Your competent, innovative partner for the optimization of overall concepts.

Operating method of the Kendrion electromagnetic clutch for A/C compressors

Kendrion electromagnetic clutches for A/C compressors are the connecting link for transmitting power between crankshaft and compressor. The A/C system is engaged/disengaged as required via the clutch. This means specific utilization that positively improves the energy balance.

Kendrion clutches are used with all common A/C compressors. They are mounted directly to the compressor and usually belt-driven.

General design of Kendrion compressor clutches:

- The electromagnet (1) is fastened to the housing.
- The rotor (2) is connected with the shaft of the unit to be driven („shaft-mounted“, see figure) or mounted on the compressor („housing-mounted“).
- The armature plate (3) with the spring (4) is connected with the drive.
- When the magnet is energized, the electromagnetic flux passes through the rotor into the armature disc (see figure) and thus closes the circuit.
- The magnet flux presses the armature plate against the rotor and connects it with the clutch by means of friction.

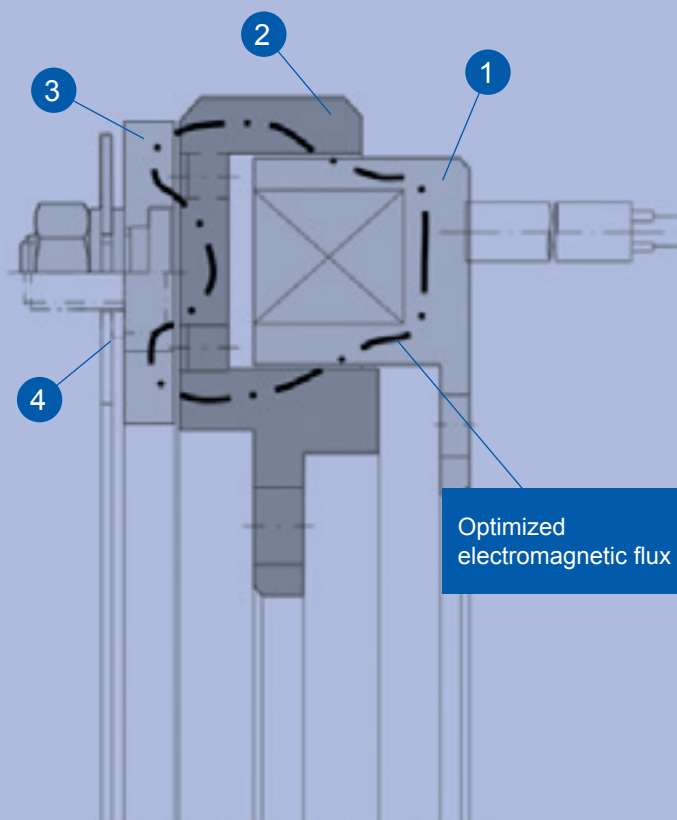

The Precautional Solutions for Special Applications: Kendrion Micro-pulsing, Slip Monitoring and Thermostatic Switches

Micro-pulsing

For very tough and demanding applications (high-temperature countries), the service life of the ball bearings can be shortened due to longer switching periods. The longer a clutch is engaged, the greater the risk for lack of ball-bearing lubrication, which can lead to damage of the bearing surfaces through false brinelling.

Kendrion solution here is to let the bearing roll off, despite the clutch being engaged. An electronic circuit, which opens the clutch for a brief moment, generates a micro-movement of the rolling elements and thus ensures lubrication of the anti-friction bearings.

Thanks to the intelligent control technology, this function can be reliably ensured independent of the wear of the clutch, without generating relevant wear itself.

Micro-pulsing for other applications

This solution may also be feasible for bearing problems on other crankshaft-mounted applications.

Why not also utilize this innovation, which was designed for Kendrion compressor clutches, for other similar applications?

Feel free to contact us!

Slip monitoring

Another preventive solution from Kendrion is our LCP (LINNIG Clutch Protection) slip monitoring. In case of errors in the vehicle's A/C system (for example too low on-board voltage, blocking of the compressor or cable breakage), slip monitoring prevents slippage by immediate disengaging of the clutch. This reliably bans the danger of overheating and associated possible consequential damages.

Both functions can be combined in a single electronic device: Kendrion LINNIG's micro-pulsing combined with slip monitoring.

The thermostatic switch

A thermostatic switch is also available from Kendrion.

We would be happy to support you in finding the optimal preventive solution for your application.

The hardness test

The comparison of the bearing surfaces after a comparative test in an engaged clutch at resonance speed with and without micro-pulsing clearly shows the result (see figures below).



Without micro-pulsing
Depth approx. 0.08 mm



With micro-pulsing
No damage detectable



How About Taking it up a Notch? The 2-speed Compressor Drive with Belt

Increasing customer requirements as to bus/coach air conditioning are a motivation for us at Kendrion Commercial Vehicle Systems that we gladly accept. Apart from the successful Kendrion On/Off A/C compressor clutches, a multi-speed solution is also available: The two-speed compressor drive with belt sets new standards. Known clutch technology that has been tried-and-tested for decades is intelligently used and further developed. As always, customers can rely on Kendrion strengths: Service-friendliness and long service life characterize this product.



The technology

The two-speed compressor drive is driven directly off the crankshaft's output pulley. The two speeds are transferred to the compressor by means of ribbed belt drives. The control is all-electrical, whereby the two clutches work alternating. The result of this system is a significant improvement, both for city bus as

well as for coach applications: With the two-speed compressor drive, the cooling capacity of A/C systems can be adapted to the specific requirements in a more controlled manner, while the compact design is still maintained.

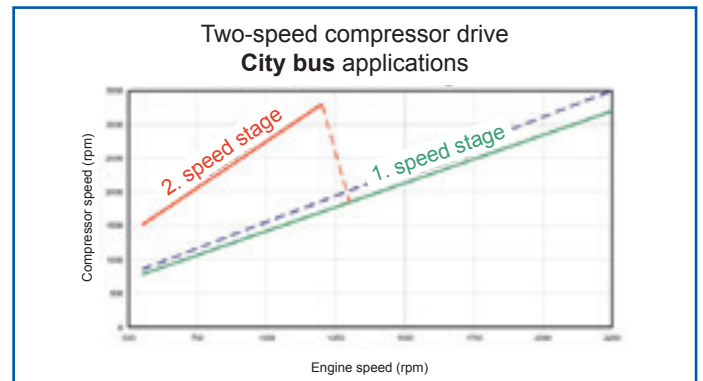
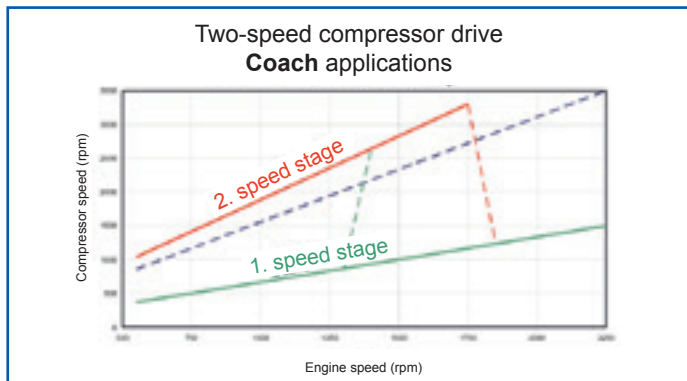

The advantages at a glance

For coach applications, the 2-speed solution convinces by improving the total efficiency through reduced fuel consumption. As an added bonus, the low noise emission increases passenger comfort.

For city bus applications, the cooling capacity is increased at low engine speed – a decisive advantage, especially in countries with high temperatures as well as when standing at bus stops.

Comfort, efficiency and environmental protection

With Kendrion two-speed compressor drive, entering a heated-up bus is a thing of the past, even when the bus has been waiting in the blazing sun. Thanks to Kendrion LINNIG's technology, the compressor speed can be increased by more than 70%. As this takes place without increasing the engine speed, the more on comfort is not at the expense of the environment: Increased fuel consumption and pollution emission are prevented.

system is operated in a more favorable efficiency degree, which also helps reduce the fuel consumption. Further advantages of Kendrion solution include the reduction of noise and an increased service life of the compressor.

In long-distance travel, the two-speed compressor drive also reduces the fuel consumption: Here, the A/C system can run in cycle operation and reduce the generation of heat by reducing the speed when in the 1. speed stage. Furthermore, the A/C

All in all, the two-speed compressor drive represents a consistent overall concept that combines decades of experience in clutch technology with provisos of the future. The two-speed compressor drive is the appropriate response to today's increasingly important maxims on comfort, efficiency and environmental protection.

Interested in Other Areas of the Kendrion Commercial Vehicle Systems Portfolio?



1



2

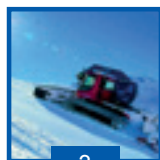

3



4



5



6



7



8



9



10

Industries

- | | |
|-----------------------------------|-----------------------------|
| 01 Busses/Coaches | 06 Rail Vehicles |
| 02 Trucks | 07 Municipal Vehicles |
| 03 Off Highway | 08 Agricultural Engineering |
| 04 Fire-prevention Technology | 09 Construction Machinery |
| 05 General Mechanical Engineering | 10 Industrial Engines |

Product Portfolio

- | | |
|--|-------------------------------------|
| a Electromagnetic Fan Clutches | f Hydraulic Clutches |
| b Angle Gears | g Shutting-speed Regulators |
| c A/C Compressor Clutches | h Torsional Vibration Dampers |
| d Electromagnetic Clutches for Auxiliary Units | i Clutches for Special Applications |
| e Pneumatic Clutches | j Tensioning and Deflection Rollers |



a



b



c



d



e



f



g



h



i



j

For more information, please log on to www.kendrion.com



WE MAGNETISE THE WORLD

Service is not a task for us, it's a part of doing good business.

After delivery and installation, Kendrion customers will certainly not be left alone. Our qualified personnel will gladly answer any technical questions.

Expect swift and competent service over our hotline:

+49 7544 964-0.

Kendrion Commercial Vehicle Systems – Global Production Sites and Sales Locations

Kendrion (Markdorf) GmbH Commercial Vehicle Systems

Riedheimer Strasse 5
88677 Markdorf
Germany

Phone: +49 7544 964-0
Fax: +49 7544 6218
webinfo.markdorf@kendrion.com
www.kendrion.com

Kendrion LINNIG India Pvt. Ltd.

Klaus Union Campus
Gat no 1197
Near Ghotawade Phata, Village Pirangut
Taluka Mulshi, Dist Pune 412 108
India

sameer.deshmukh@kendrion.com

Kendrion (São Paulo) Sistemas Automotivos Ltda.

R. Silvério Finamore, 920
Cond. Industrial, Galpão 03
13290-000 Louveira, S.P.
Brazil

Phone: +55 19 3848 9900
vendas.saopaulo@kendrion.com

Kendrion Toluca, S.A. de C.V.

Camino a Ocotitlan No. 110
Col. La Estación
Mexicaltzingo, Toluca,
Edo. de México, 52180
Mexico

Phone: +52 (722) 263 2735
Fax: +52 (722) 263 2739
ventas@linnig.com.mx

Kendrion Linnig Drive Tech. (Nanjing) Co. Ltd.

Qi Xia Economic Development Zone,
Runhua Road 14#
210034 Nanjing
China

Phone: +86 25 83318982
Fax: +86 25 83308976
linnig@linnig.com.cn

Kendrion (Shelby) Inc.

1100 Airport Road
Shelby, NC 28150-3699
USA

Phone: +1 704 482 9582
Fax: +1 704 481 1741
sales.shelby@kendrion.com